



Descale Procedure

This instructional manual is intended to provide instructions for the proper descale of the Noritz Tankless Water Heater. Failure to adhere to the instructions of this manual may result in voiding the warranty.

There are multiple versions of the descaling instructions depending on the generation of water heater installed. Refer to the chart below to locate the proper set of instructions. Contact Noritz Technical Support (866-766-7489) for additional support.

Group A (pg. 3)	Group B (pg. 6)	Group C (pg. 12)
NR501	NR83 (GQ-2457 Series & later)	All other models not listed in group A or B
NR662	NRC98 (GQ-C2857 Series & later)	
NRC661	NR98 (GQ-2857 series & later)	
NRC711	NRC111 (GQ-C3257 series & later)	
NRC663 (EZTR40)	EZ98 (GQ-C2859 series & later)	
	EZ111 (GQ-C3259 series & later)	
	NRCR92 (GQ-C2660 series & later)	
	NRCR111 (GQ-C3260 series & later)	

Scan QR Code Below for Video Tutorial



Noritz America Corporation

11160 Grace Avenue, Fountain Valley, CA 92708 Phone 866-766-7489 Fax 714-241-1196

If this Water Heater will be installed in a location where the hardness of the supply water is high, scale Build-up may cause damage to the Heat Exchanger.

Perform suggested treatment and maintenance measures to be taken based on the water hardness level according to the below table.

Treatment Guidelines

Type of Water	Hardness Level	Treatment Device*	Flush Frequency**
Soft	0-1 gpg (0-17 mg/L)	None	None
Slightly Hard	1-3 gpg (17-51 mg/L)		
Moderately Hard	3-7 gpg (51-120 mg/L)	Scale Shield or Water Softener	Once a Year***
Hard	7-10 gpg (120-171 mg/L)		
Very Hard	10-12 gpg (171-200 mg/L)		
Extremely Hard	> 12 gpg (> 200 mg/L)		

* When selecting a treatment device, you must consult with the device's spec sheet and installation manual for guidelines and limitations. Not all water supplies are compatible. A water test may be required.

** Install Noritz Isolation Valves to allow for flushing.

*** Flushing is required if a water treatment device is not installed.

NOTE Damage to the Water Heater as a result of the items below is not covered by the Noritz America Limited Warranty.

- Water in excess of 12 gpg (200 mg/L) of hardness
- Poor water quality (See the Water Quality List on page 12.)
- The Remote Controller has displayed a "C1# (Service Reminder)" indicating Scale Build-up, but the Heat Exchanger has not been flushed.

Noritz America Corporation

11160 Grace Avenue, Fountain Valley, CA 92708 Phone 866-766-7489 Fax 714-241-1196



Descaling Procedure Group A Zone II

This instructional manual is only intended for use by a qualified service professional or authorized Noritz Service Representative. Any unauthorized use of this manual may result in voiding the warranty.

Please contact Noritz Technical Support (866-766-7489) for additional support.

Applicable Models :

- NR501-OD
- NR662-OD
- NRC661A-OD
- NRC661A-DV
- NRC711-OD
- NRC711-DV
- NRC663-FSV (EZTR40)

Noritz America Corporation

11160 Grace Avenue, Fountain Valley, CA 92708

Phone 866-766-7489 Fax 714-241-1196

Procedure for Flushing the Heat Exchanger - ZONE II

This procedure is only intended for use by a qualified service professional or authorized Noritz Service Representative. Any unauthorized use of this procedure may result in voiding the warranty. Please contact Noritz America (866-766-7489) for additional support.

If the error code “C*#*~C*#*” is flashing on the Display Window, it means there is Scale Build-up in the Heat Exchanger. The Heat Exchanger needs to be flushed** to remove the Scale Build-up. Damage to the water heater due to Scale Build-up is not covered by the water heater's warranty.

To clear the error code “C*#*~C*#*”, the Heat Exchanger must be flushed.

If the error code “C*#*” is displayed and flashing in the Display Window, please contact Noritz America (866-766-7489).

* * = 1, 2, 3, 4, F

= 1, 2, 3, 4, 5, 6, 7, 8, 9, A, b, C, d, E, F

** Connect the “blue connector” for flushing on the Circuit Board when flushing the Heat Exchanger. After connecting it, the water heater is set to “Flushing Mode”.

The water heater must remain connected to electrical power when flushing the Heat Exchanger.

« 1. The preparation of the flushing system »

1. Close the gas supply valve.
2. Close the water inlet valve (V1) and the water outlet valve (V2).
3. Connect the one drain hose (H1) to the drain valve (V3), and then the other to the circulating pump.
4. Connect the drain hose (H2) to the circulating pump.
5. Connect the drain hose (H3) to the drain valve (V4).
6. Pour 1 gallon of “Calcium, Lime and Rust Removal Product” and 1 gallon water into the bucket.
- Noritz recommends “Calcium, Lime and Rust Removal Product” for flushing.
7. Place the both drain hoses (H2 and H3) into the bucket filled with the flushing solution.
8. Open the both drain valves (V3 and V4).

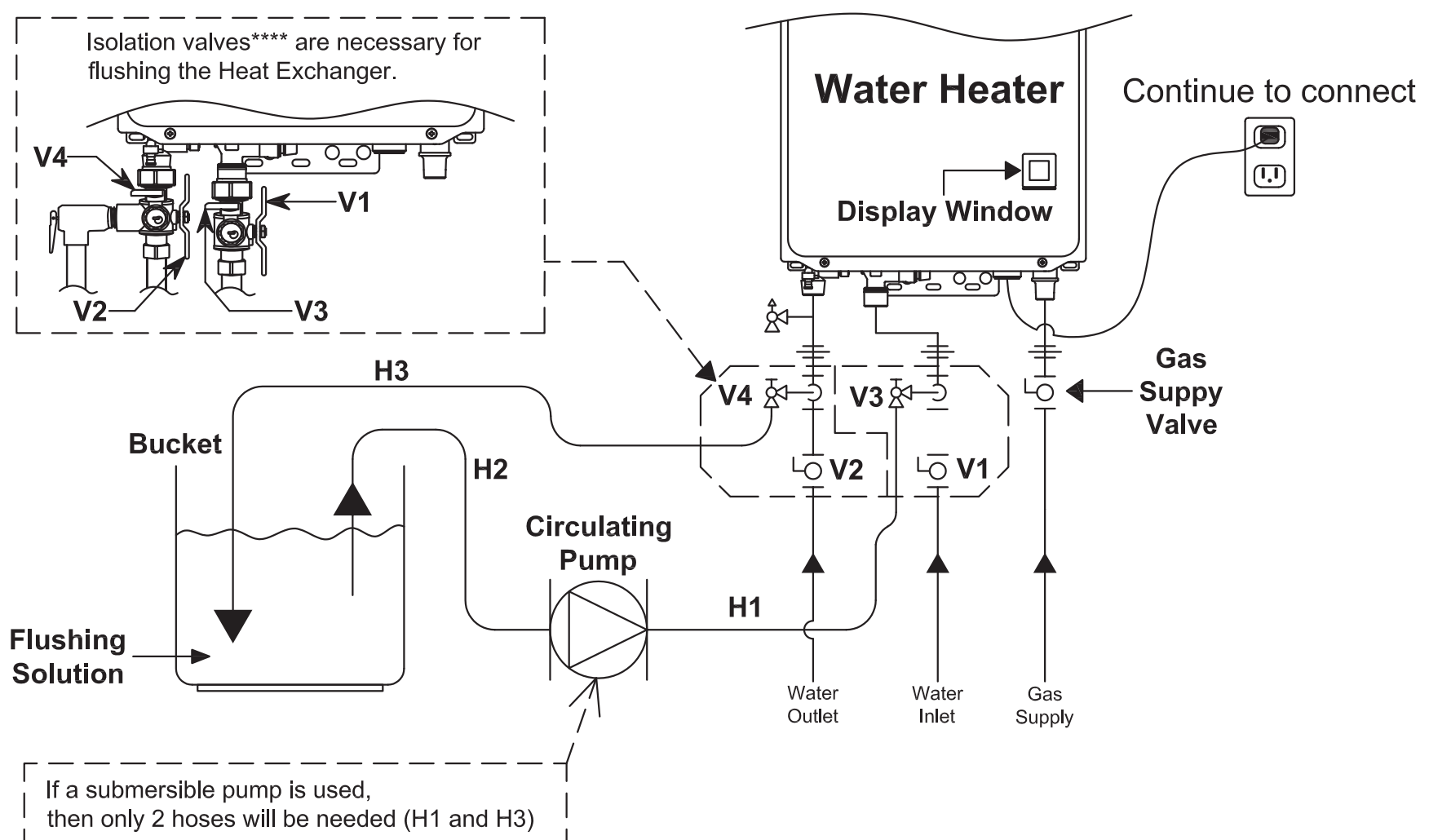

**** Isolation valves may be purchased as an accessory from an authorized Noritz wholesaler. They allow for full diagnostic testing and easy flushing of the system. Contact Noritz America for more information (866-766-7489).

« 2. Flushing the Heat Exchanger »

1. Open the Front Cover.
2. Connect the “blue connector****” for flushing on the Circuit Board.

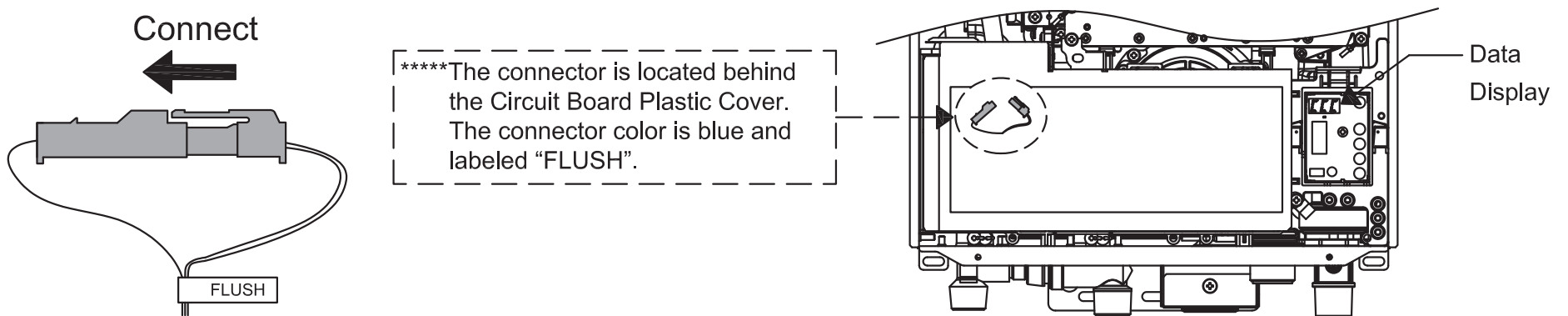

3. Then the code “CCC” is displayed on the Data Display.

4. Turn on the circulating pump to circulate the flushing solution through the water heater for 1 hour at a rate of 1.5 gallons per minute or more.
5. The code “C60” is displayed on the Data Display when the water heater detects the flow of the flushing solution.

When 1 minute passes, the code “C60” will change to “C59” on the Data Display.



Please check whether the reverse connection of the hose (H1) and (H3) if the display number will not change. In that case, the flow rate of the flushing solution may be under 1.5 gallons per minute.

6. When 1 hour passes, the code “C00” is flashing on the Data Display. Flashing
Do not disconnect the “blue connector for flushing” on the Circuit Board.
7. Turn off the circulating pump.

« 3. Cleaning the Heat Exchanger »

The flushing solution needs to be rinsed and cleaned out of the water heater. Below is the way to rinse and clean the flushing solution.

1. Remove both drain hoses (H2 and H3) from the bucket. And then place the drain hose (H3) into the sink or outside to drain.
2. Close the drain valve (V3) and then open the water inlet valve (V1). Do not open the fresh water outlet valve (V2).
3. Clean the water heater with fresh water for 3 minutes or more. (Needs to have enough time to clean the water heater.)

NRC663-FSV (EZTR40) has a "Water Drain Valve" on the bottom of the water heater. Place the bucket under the water heater to drain water from the Water Drain Valve. Carefully unscrew the "Water Drain Valve" to rinse flushing solution out of the water heater for about 10 seconds, then close the "Water Drain Valve".

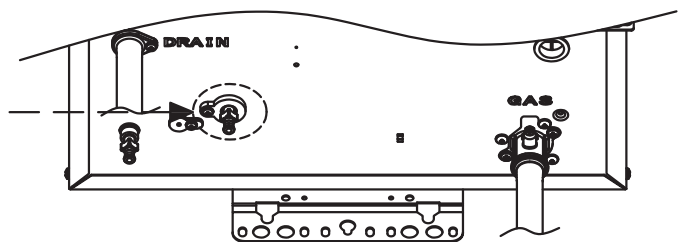

4. Close the drain valve (V4) and then remove the drain hose (H3) from the drain valve (V4).
5. Remove the drain hose (H1) from the drain valve (V3).
6. Disconnect the “blue connector for flushing” on the Circuit Board. The code “C00” goes out on the Data Display.
7. Close the Front Cover.
8. Open the gas supply valve and water outlet valve (V2).
9. Check for correct operation of the water heater.

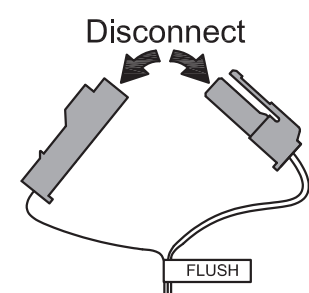

The water heater can not operate if the “blue connector” for flushing is connected.

Please contact Noritz America if more information is needed for flushing.
(Phone # : 866-766-7489)



Scan for Video Tutorial



Descal Procedure Group B Zone III

This instructional manual is only intended for use by a qualified service professional or authorized Noritz Service Representative. Any unauthorized use of this manual may result in voiding the warranty.

Please contact Noritz Technical Support (866-766-7489) for additional support.

Applicable Models :

- GQ-2457 Series
- GQ-2857 Series
- GQ-C2857 Series
- GQ-C3257 Series
- GQ-C3259 Series
- GQ-C3260 Series

Noritz America Corporation

11160 Grace Avenue, Fountain Valley, CA 92708

Phone 866-766-7489 Fax 714-241-1196

Procedure for Flushing the Heat Exchanger - ZONE III

This procedure is only intended for use by a qualified service professional or authorized Noritz Service Representative. Any unauthorized use of this procedure may result in voiding the warranty. Please contact Noritz America (866-766-7489) for additional support.

If the error code “C*#*~C*#*” is flashing on the Remote Controller (or Operation Panel**), it means there is Scale Build-up in the Heat Exchanger. The Heat Exchanger needs to be flushed*** to remove the Scale Build-up.

Damage to the water heater due to Scale Build-up is not covered by the water heater's warranty.

To clear the error code “C*#*~C*#*”, the Heat Exchanger must be flushed.

If the error code “C*#*” is displayed and flashing on the Remote Controller (or Operation Panel**), please contact Noritz America (866-766-7489).

* * = 1, 2, 3, 4, F / # = 0, 1, 2, 3, 4, 5, 6, 7, 8, 9

** NR98DVC(GQ-2857WX-FFA US) and NR83DVC(GQ-2457WS-FFA US) only.

*** Connect the “blue connector for flushing” near the Circuit Board when flushing the Heat Exchanger.

After connecting it, the water heater is set to “Flushing Mode”.

The water heater must remain connected to electrical power when flushing the Heat Exchanger.

Basic Procedure

«Procedure 1. The preparation of the flushing system»

1. Close the gas supply valve.
2. Close the water inlet valve (V1) and the water outlet valve (V2).
3. Connect the one drain hose (H1) to the drain valve (V3), and then the other to the circulating pump.
4. Connect the drain hose (H2) to the circulating pump.
5. Connect the drain hose (H3) to the drain valve (V4).
6. Pour 1 gallon of “Calcium, Lime and Rust Removal Product” and 1 gallon water into the bucket.
- Noritz recommends “Calcium, Lime and Rust Removal Product” for flushing.
7. Place the both drain hoses (H2 and H3) into the bucket filled with the flushing solution.
8. Open the both drain valves (V3 and V4).

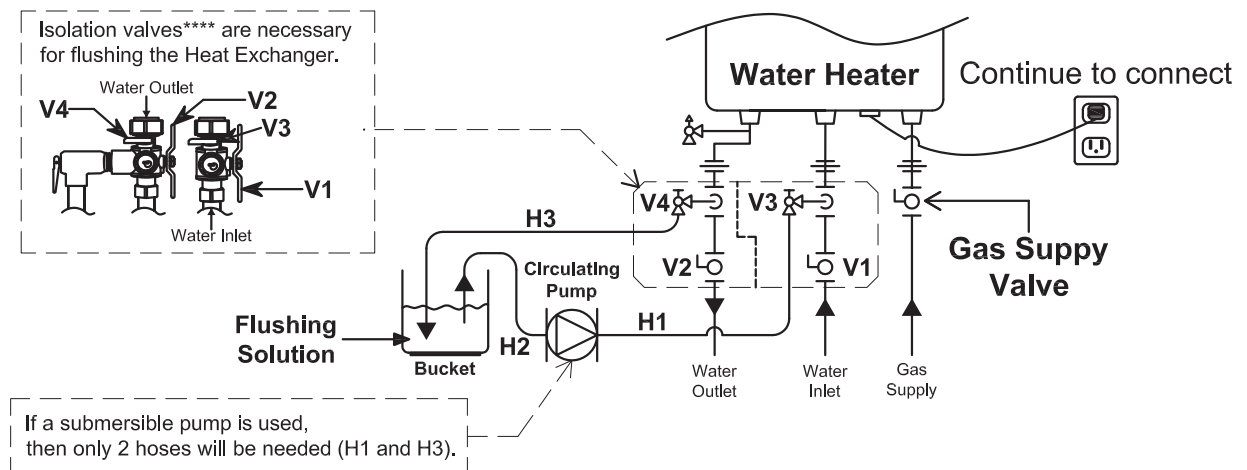

**** Isolation valves may be purchased as an accessory from an authorized Noritz wholesaler. They allow for full diagnostic testing and easy flushing of the system. Contact Noritz America for more information.(866-766-7489)

«Procedure 2. Flushing the Heat Exchanger – For Single Unit»

1. Open the Front Cover.
2. Connect the “blue connector*****” for flushing near the Circuit Board.

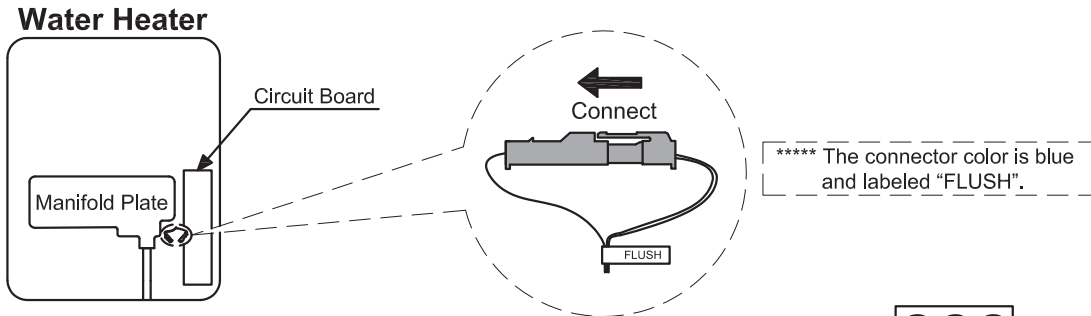

3. Then the code “CCC” is displayed on the Remote Controller. **CCC**
4. Turn on the circulating pump to circulate the flushing solution through the water heater for 1 hour at a rate of 1.5 gallons per minute or more.
5. The code “C60” is displayed on the Remote Controller when the water heater detects the flow of the flushing solution.

When 1 minute passes, the code “C60” will change to “C59” on the Remote Controller.



Please check whether the reverse connection of the hose (H1) and (H3) if the display number will not change. In that case, the flow rate of the flushing solution may be under 1.5 gallons per minute.

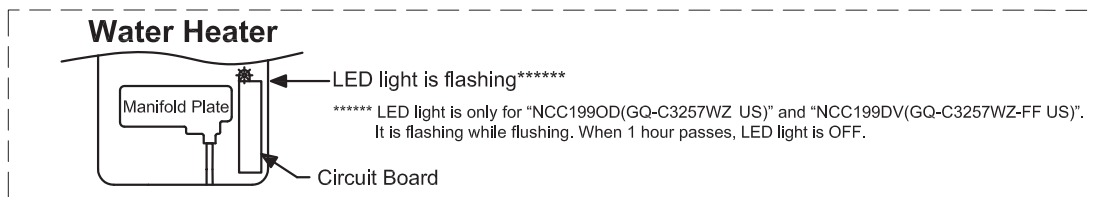

6. When 1 hour passes, the code “C00” is flashing on the Remote Controller. **C00** Flashing
Do not disconnect the “blue connector for flushing”.

7. Turn off the circulating pump.

«Procedure 3. Cleaning the Heat Exchanger»

The flushing solution needs to be rinsed and cleaned out of the water heater. Below is the way to rinse and clean the flushing solution.

1. Remove both drain hoses (H2 and H3) from the bucket. And then place the drain hose (H3) into the sink or outside to drain.
2. Close the drain valve (V3) and then open the water inlet valve (V1).
Do not open the fresh water outlet valve (V2).
3. Clean the water heater with fresh water for 3 minutes or more.
(Needs to have enough time to clean the water heater.)

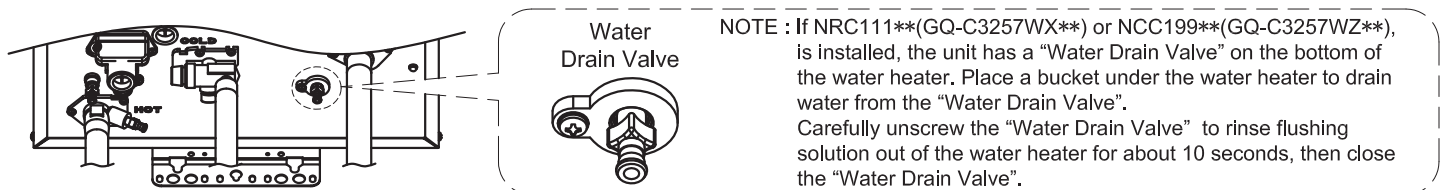

4. Close the drain valve (V4) and then remove the drain hose (H3) from the drain valve (V4).
5. Remove the drain hose (H1) from the drain valve (V3).
6. Disconnect the “blue connector for flushing” near the Circuit Board.
The code “C00” goes out on the Remote Controller.
7. Close the Front Cover.
8. Open the gas supply valve and water outlet valve (V2).
9. Check for correct operation of the water heater.

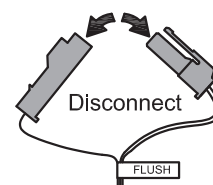

In case of the “Quick Connect Multi System Procedure”

1. Connect the “blue connector for flushing” of need to be flushed.
(The water heater is isolated from Quick Connect Multi system when the “blue connector for flushing” is connected. Not need to disconnect the Quick Connect Cord.)

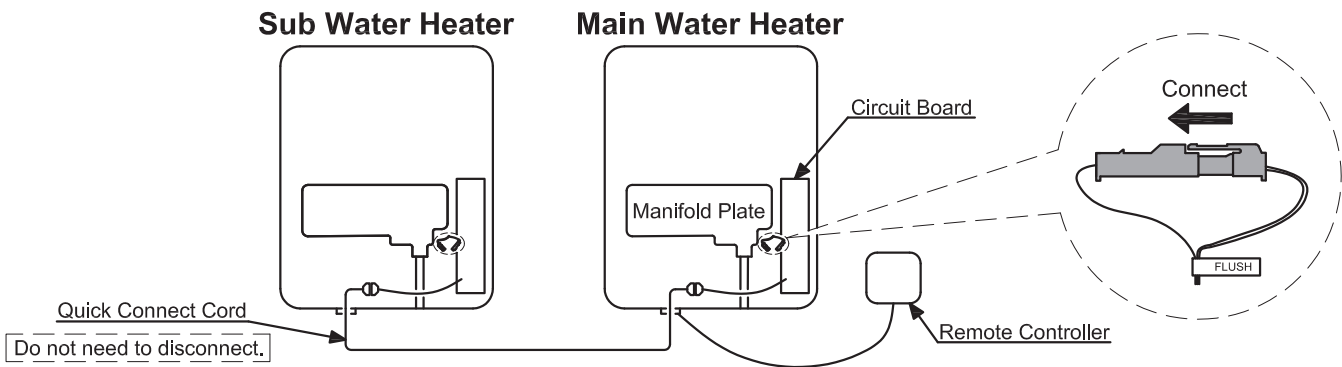

2. Then the code “CCC” or “FCC” is displayed on the Remote Controller.

CCC is displayed when the Main Water Heater's blue connector is connected.

FCC is displayed when the Sub Water Heater's blue connector is connected.

2. Turn on the circulating pump to circulate the flushing solution through the water heaters for 1 hour at a rate of 1.5 gallons per minute or more.

(LED light is flashing while flushing the heat exchanger. See the “Procedure 2.5”.)

3. When 1 hour passes, the code “C00” is flashing on the Remote Controller.

Do not disconnect the “blue connector for flushing”.



(Ex. : The display when the both water heaters are flushed at the same time.)

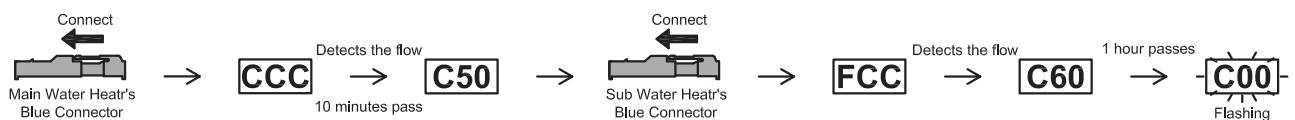

The remaining time of flushing gives indication priority to the connector which is connected later.

4. Turn off the circulation pump.
5. Rinse and clean the flushing solution out of the water heaters in accordance with “Procedure 3”.
(See the “Procedure 3.1-3.5”.)



Water Drain Valve

NOTE : Place a bucket under the water heater to drain water from the “Water Drain Valve”. Carefully unscrew the “Water Drain Valve” to rinse flushing solution out of the water heater for about 10 seconds. Then close the “Water Drain Valve”.

6. Disconnect the “blue connector for flushing”. The Code “C00” goes out on the Remote Controller.
7. Close the Front Covers.
8. Open the gas supply valves and water out let valves.
9. Check for correct operation of the water heaters.

In case of the “Multi System Procedure”

1. Connect the “blue connector for flushing” of need to be flushed.
(The water heater is isolated from Multi System when the “blue connector for flushing” is connected. Not need to disconnect the “Cord for the Multi System” .)

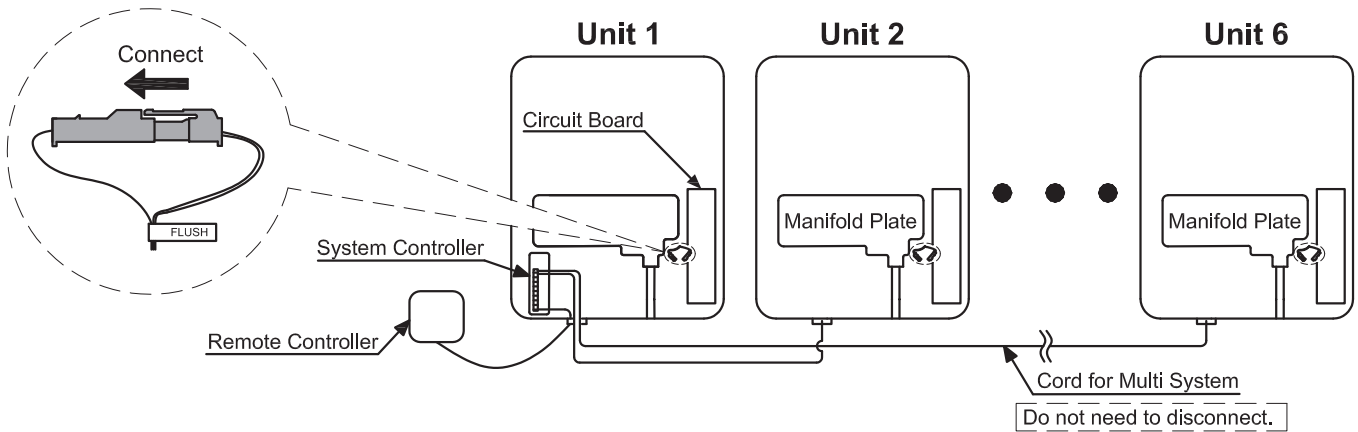

2. Then the code “CCC” is displayed on the Remote Controller and the error alarm continuously sounds. Press the “ALARM OFF” button to stop the error alarm.

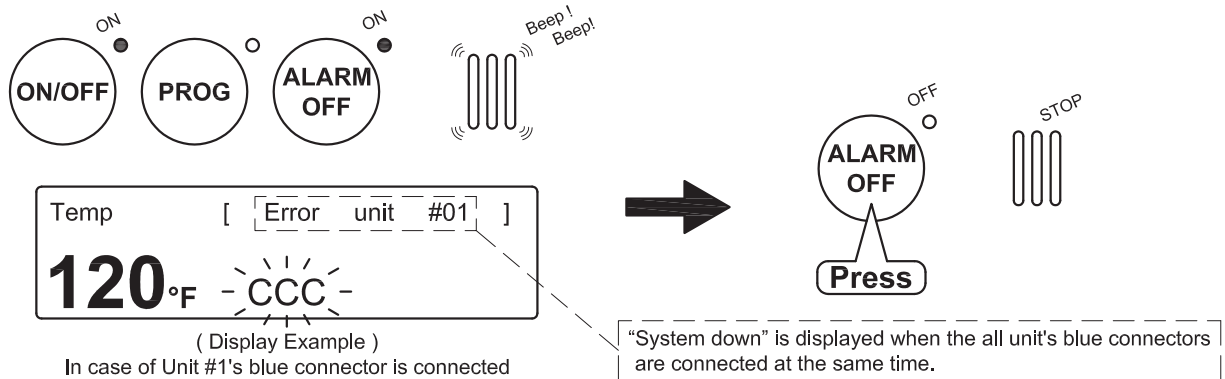

3. Turn on the circulating pump to circulate the flushing solution through the water heaters for 1 hour at a rate of 1.5 gallons per minute or more.
Note : The code “CCC” does not change when Multi System mode. The display does not show the remaining time of flushing.
4. Check for the remaining time of flushing to see the Maintenance Monitor #80 (MM #80).

«How to check the remaining time of flushing»

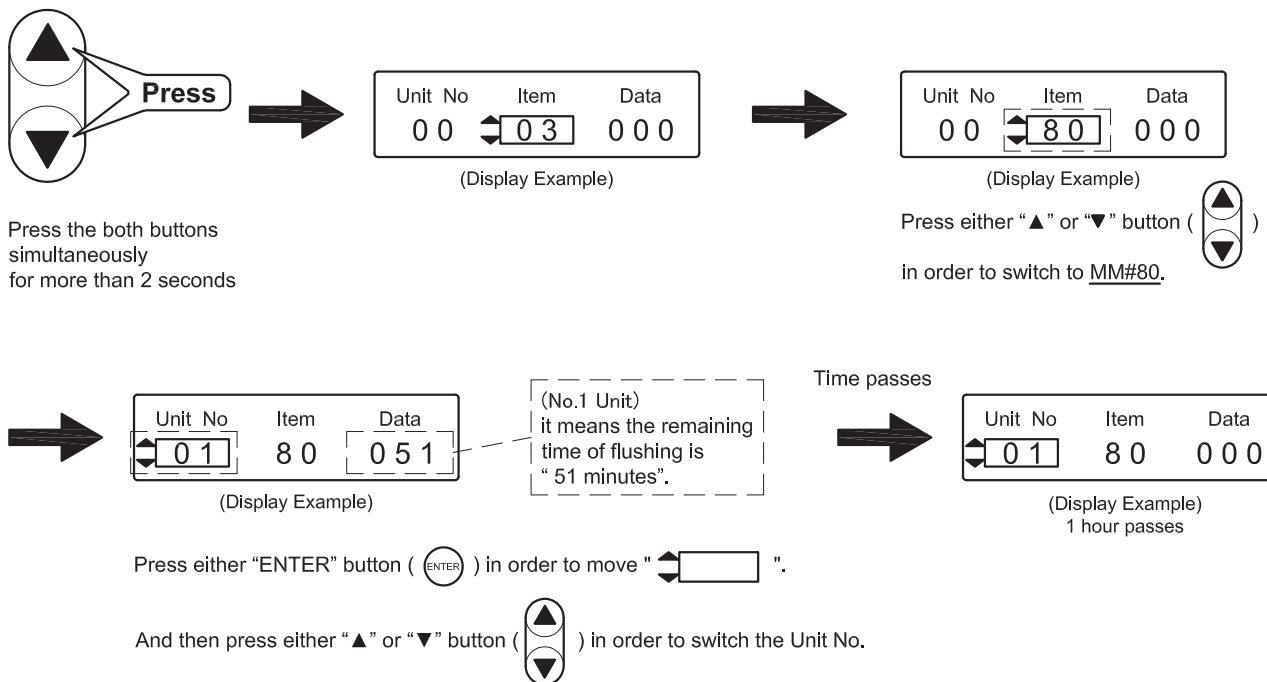

5. When 1 hour passes, turn off the circulation pump.
(LED light is flashing while flushing the heat exchanger. See the "Procedure 2.5".)
6. Rinse and clean the flushing solution out of the water heaters in accordance with "Procedure 3".
(See the Procedure 3.1~3.5.)

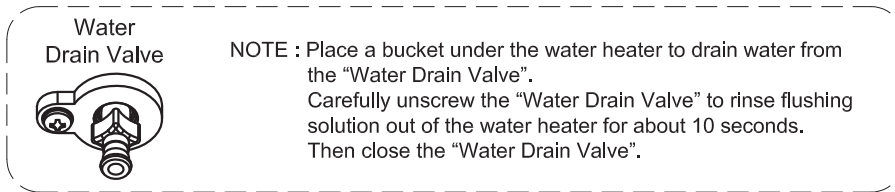

7. Disconnect the "blue connector for flushing". The Code "CCC" goes out on the Remote Controller.
8. Close the Front Covers.
9. Open the gas supply valves and water outlet valves.
10. Check for correct operation of the water heaters.

Please contact Noritz America if more information is needed for flushing.
(Phone # : 866-766-7489)



Scan for Video Tutorial



Descale Procedure Group C

This instructional manual is only intended for use by a qualified service professional or authorized Noritz Service Representative. Any unauthorized use of this manual may result in voiding the warranty.

Please contact Noritz Technical Support (866-766-7489) for additional support.

Applicable Models:

- N-042
- N-063
- N-084
- N-132
- N-063S Series
- N-069M Series
- N-084M Series
- N-132M Series
- N-0531S Series
- N-0631S Series
- N-0751M Series
- N-0841MC Series
- N-0842MC Series
- N-0931M Series
- N-1321M ASME
- NR50-OD
- NR66 Series
- NR71 Series
- NR98 Series
- NC199 Series
- NRC111 Series
- NCC199 Series
- NR111 Series
- NC250 Series
- NC380-SV-ASME
- NRC661 Series (Not A)
- NR83-DVC
- NRC83 Series
- NRC98 Series
- NR981 Series
- NC1991 Series
- NRC1111 Series
- NCC1991 Series
- NCC1992-DV

Noritz America Corporation

11160 Grace Avenue, Fountain Valley, CA 92708

Phone 866-766-7489 Fax 714-241-1196

Flushing Procedure C

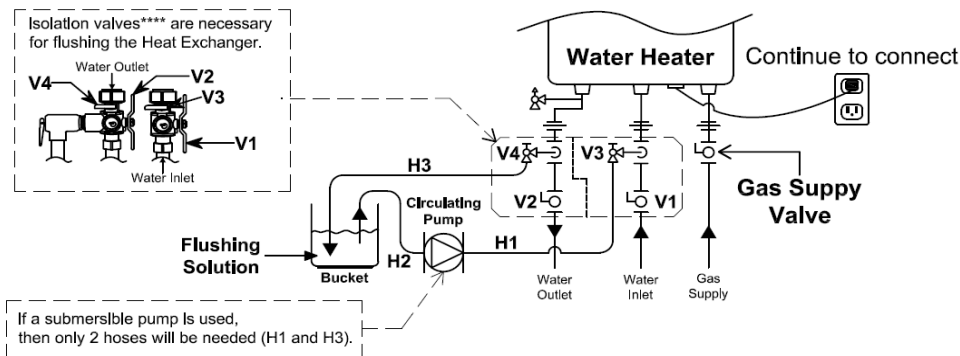

**** Isolation valves may be purchased as an accessory from an authorized Noritz wholesaler. They allow for full diagnostic testing and easy flushing of the system. Contact Noritz America for more information.(866-766-7489)

1. Turn the power ON/OFF Button "on" on the remote controller, and then set temperature "140°F" by pressing the UP Button. (It's for closing the "Water Servo-Bypass".)

If your unit is N-132, N-132M, N-1321M or NC380 series, the temperature needs to be set at 145°F by pressing the UP;

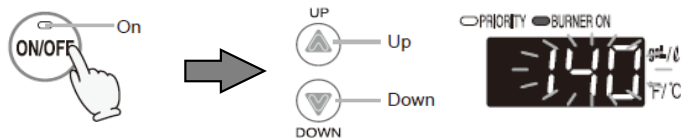

2. Open the "V2 Valve" (run water). And then the unit will begin to operate*.
*Close the "Valve V4 and V3" when the unit is running.
3. Confirm "MM60*" and "MM62**" when the unit is running.
Please wait for a few minutes until the "Water Servo-Main" is fully open and the "Water Servo-Bypass" is closed.

*MM60 : This MM# shows the position of "Water Servo-Main".
Should be "000" for fully open.

**MM62 : This MM # shows the position of "Water Servo-Bypass".
Should be "1275" or higher for fully closed.

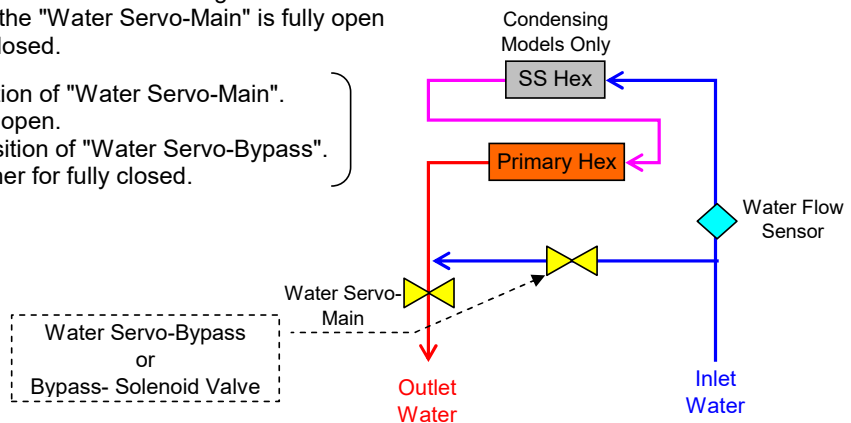

4. Unplug the water heater from electrical power, and then close the "Gas Supply Valve, V1 and V2 Valves".
5. Pour 1 gallon of "Calcium, Lime and Rust Removal Product" and 1 gallon water into the bucket.
6. Place both drain hoses (H2 and H3) in the bucket filled with the flushing solution.
7. Open the "V3 Valve" and "V4 Valve" for flushing.
8. Turn the circulating pump to circulate the flushing solution for 1 hour.
9. 1 hour passes, turn off the circulation pump.
10. Remove both drain hoses (H2 and H3) from the bucket
11. Place the drain hose (H3) into the sink or outside to drain.
12. Close the "V3 Valve", and then open the "Water Inlet Valve (V1)".
Don't open the "Water Outlet Valve (V2)".

13. Clean the water heater with fresh water for 3 minutes or more to rinse the flushing solution.
 For Condensing units only : Place a bucket under the water heater to drain water from the "Water Drain Valve".
 Carefully unscrew the "Water Drain Valve" to rinse the flushing solution, and then close it.

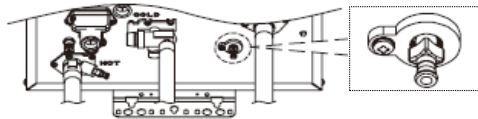

Water Drain Valve
 (Condensing Units Only)

14. Close the "V4 Valve", and then remove both drain hoses (H1 and H3).
 16. Plug the water heater into electrical power, and the power ON/OFF Button "on" on the remote controller.



17. Open the "Water Outlet Valve (V2)" and "Gas Supply Valve".
 18. Check for the correct operation of the water heater.